





Bits 起子頭

P: Point size of front end

P	Size (mm)
00#	0.8~0.9
0#	0.9~1.0
1#	1.3~1.4
2#	2.2~2.3

Type of Bit Holder

"A"-Bit in SS 5mm, Hexagon Type 	=> Hex5.0
"B"-Bit in SS 6.35mm, Hexagon Type 	=> Hex6.35
"C"-Bit in M3 4Ø Round Type 	=> HB4.0
"D"-Bit in M6 5Ø Round Type 	=> HB5.0

Holder: A or B

*Shrink of front section (前端有縮)

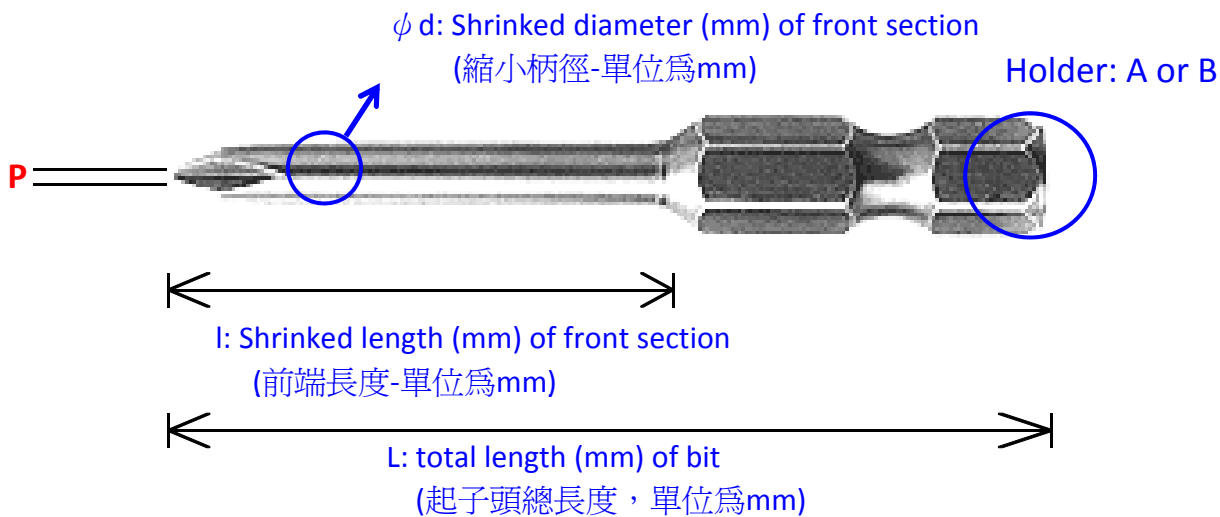

*No Shrink of front section (前端沒有縮)

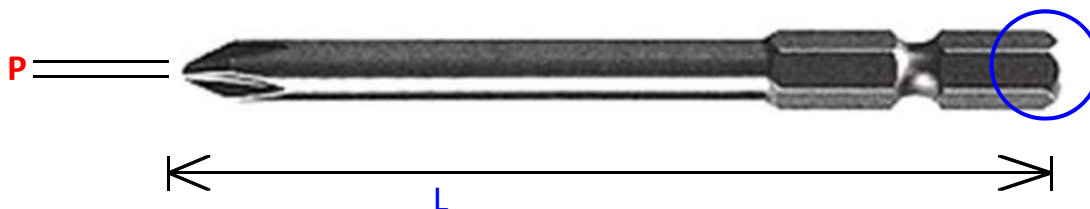

Holder: C or D

***Shrink of front section (前端有縮)**

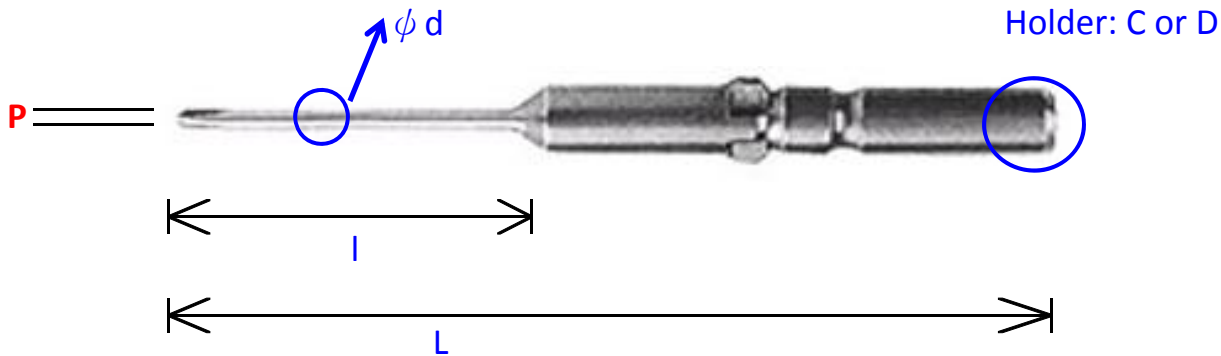

***No Shrink of front section (前端沒有縮)**

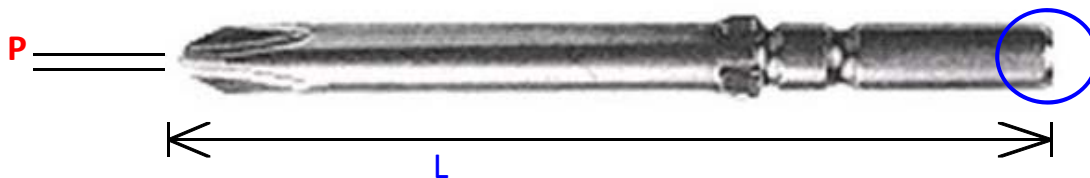

Single end 單頭







S5, S6.35

Double end 雙頭



SS5, SS6.35

1.		Phillips	十字
2.		Slotted	一字
3.		Torx	T5, T6, T7, T8, T9, T10, T15.....
4.		Torx Plus	
5.		Pozidriv	

