

Dear Partners,

Enclosed please find a PowerPoint file of **Industry 4.0: An Invisible World Competition and Trend_20151216A** for your reference.

It can be served as a material for sales and seminars.

The newly developed products will be updated and added additional pages in the future.

Best regards,

Loover-Kilews Industrial Co., Ltd.



Industry 4.0: An Invisible World Competition and Trend



1. What is the difference between industry 4.0 and three previous industrial revolutions?

The biggest difference between Industry 4.0 and three previous industrial revolutions is that no longer to the productivity demand of the manufacturing side as a starting point, ***but will be the value demand of the client side as a starting point for the entire industry chain.***

The concept of industry 4.0 has three support points:

- a. The value of manufacturing itself is not just to do a product, but also to reduce the waste of the production process to a minimum.
- b. Let the system during the manufacturing process is automatically adjusted according to the changes of product processing status, and achieve the self-aware function of the system on the basis of the original automation.
- c. To achieve zero fault, zero risk, zero accident and zero pollution in the entire manufacturing process which is the highest level of manufacturing system.

2. Sell to the user is no longer the product but valuable ability in the future

Industry 4.0 will connect the end user and the manufacturing system through the data, these data will automatically determine the decision of all aspects of the production system, to achieve the production chain of upstream and downstream integration, the working difficulty of the people will be greatly reduced, in this mode the organization of the plant will become flat, the use of production resources will also be more optimized.

3. The ultimate goal: to find and meet the invisible value gap

The revolution of manufacturing industry is a basic condition to achieve industry 4.0, *its most fundamental driving force comes from the innovative technological change of business model and intelligent service system, which are the key to the future industrial competition.*

The opportunity space of the future industry can be divided into four parts:

- a. To meet the user's visible needs and solve visible problems.
- b. To avoid visible problems and needs to dig new knowledge from the data in use, add value to existing production systems and products.
- c. To use innovative methods and technologies to solve the unknown problems.
- d. To find and meet the invisible value gap and avoid the impact of invisible factors, *this part needs to use intelligence information generated by data analysis to create new knowledge and values, which is the ultimate goal of industry 4.0.*

4. Application of industry 4.0

Another feature of industry 4.0 is the extension of the manufacturing process and value to the use of the process, not only concerned about a product manufactured, but also should be concerned about how to use this product to achieve the maximum value of the product. ***Of course, we have all heard a maxim: to do his work well, must first sharpen his tools. To make the good products, it is necessary to return to the source, that is, must have good tools, such as Kilews Power Torque Series and Cordless Battery Series Screwdrivers.***

Please link the following catalogues for your reference:

http://www.loover.com.tw/en/download/BN_Power_Torque_EN201410R1.pdf

http://www.loover.com.tw/en/download/kilews_cordless_screwdriver_201509.pdf

Innovation for screw fastening



KILEWS



‘Innovative’ Power Torque Series Electric Screwdriver



Loover





Kilews Power Torque Series VS. Industry 4.0

The competition with development of industry 4.0, Kilews Power Torque electric screwdrivers toward brushless, intelligent, wireless operation as the main research and development, the counter controller (SKP-BC40HL v3.0 / SKP-BC40HL-800 v3.0) can connect with PLC and display the number of unfinished screw counts to prevent the operation error and include I/O function for production management, in line with world's energy saving and carbon reduction green tools.

ELECTRICAL VS. PNEUMATIC SCREWDRIVER

Electrical vs. Pneumatic Screwdrivers

	Electric	Pneumatic
Energy consumption	✓	✗
CO2 Emission	✓	✗
Cost of investment	✓	✗
Cost of operation	✓	✗
Maintenance	✓	✗
Noise level	✓	✗



An electronic is a more eco friendly alternative

Cost Example

Energy / Cost ratio 55:1

	Number of screws per day	Operating time hour per day	Working day	Air consumption m ³ / Year	Energy consumption kWh / Jahr	Power cost € / kWh	Cost per year
Pneumatic driver	4800	2	225	3240	356.40	€0.15	€53.46
Electrical driver	4800	2	225	---	6.5	€0.15	€0.98

Power Torque Series

Features:

- I. Brushless motor
- II. Stable high torque output
- III. Applicable for the industry of electrical engineering
- IV. Can replace pneumatic screwdriver
- V. Max torque can reach up to 35N.m
- VI. I/O function for production management



Power Torque Series Models:

Following models are categorized as power torque series:

1. SKD-BN800 series
(BN830L/P, BN830LF/PF & BN850L/P)
2. SKD-RBN series
(RBN60L/P, RBN90L/P, RBN120L/P, RBN180L/P & RBN250L/P)
3. SKD-TBN series
(TBN60L, TBN90L, TBN120L & TBN180L)
4. SKD-BN900 series
(BN960L/P, BN960LF/PF, BN990L/P & BN9120L/P)
5. SKD-BE800 series (**Built-in Counter**)
(BE830L/P, BE830LF/PF & BE850L/P)

SKD-BN800 Series

- High R.P.M. with high Torque
- Maximum speed can reach 2000r.p.m
- Noise-free & low voltage

Torque Range Chart

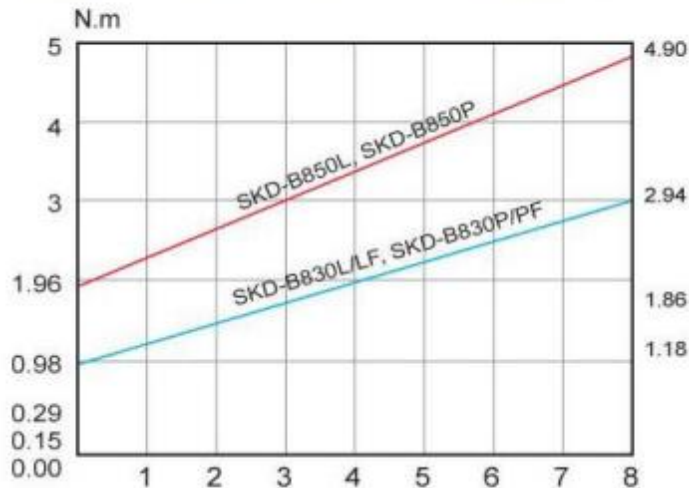

SKD-RBN (L/P TYPE) Series



- Brushless with clutch type
- RBN series can reach 35N.m
- Suitable for assembling industrial products
- Automobile parts assembly production
- Can be collaborated with auxiliary arm for easy operation

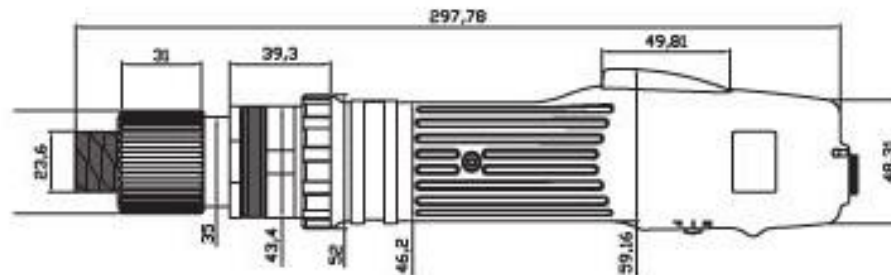

SKD-TBN (L TYPE) Series

- Best fit to assemble high torque products
- Torque for TB series can reach up to 18N.m
- Can make up for the disadvantages of pneumatic screwdriver

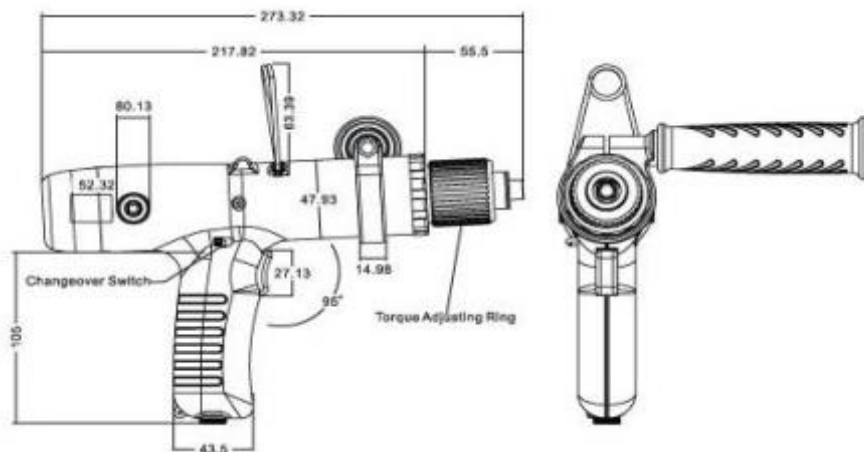

SKD-BN900 (L/P, LF/PF TYPE) Series



- Brushless with clutch type
- BN900 series can reach 12N.m
- BN960LF/PF can reach 2,200r.p.m
- Suitable for assembling industrial products

SKD-BE800 Series

- Brushless screwdriver with built-in counter
- Can program functions such as start-time, stop-time, count number & etc
- Patent is currently in progress

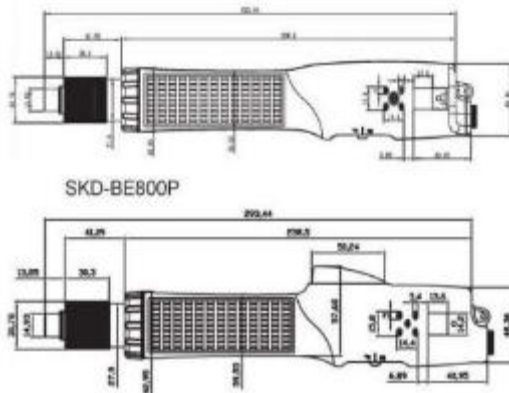

Torque Range Chart

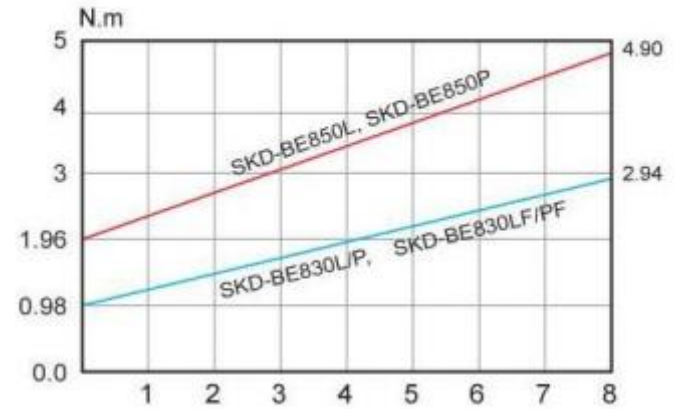

Power Controller

Power supply

SKP-40B(6P) / SKP-40B-HL-800

- Support all Power Torque Series Screwdriver
- DC32V / DC40V

SKP-40B



Power torque w/ counter

SKP-BC40HL v3.0 / SKP-BC40HL-800 v3.0

- Display the number of unfinished screw counts to prevent the operation error from neglect fastening screw
- With slow-start control
- I/O function for production management

SKP-BC40HL



Advantages:

Eco-friendly: Brushless, no carbon powder pollution, lower noise, easy to maintain.

Precision & Steady: With clutch, be free from fatigue under long-working hours.

High Torque: Power torque series 1~35N.m can replace pneumatic screwdrivers.

Impressive breakthrough: SKD-BN800 series can reach high torque and high speed, much more efficient.

Counter & PLC: SKP-BC40HL v3.0 / SKP-BC40HL-800 v3.0 display the number of unfinished screw counts to prevent the operation error & include I/O function for production management.

Application:

Assembly for Motor, Appliance or Automotive parts which require higher torque range 1~35 N.m

- Electrical Engineering
- White Goods
- Automobile Industry



Accessories:

Torque Meter KTM-250

- Widely measuring range 0.3~25N.m

Auxiliary Arm KP-AUXA + KP-VAR

- Provide with the rocker arm, enable to revolve on 360 degree
- Main shaft can be extended to maximum 830mm



KTM-CSH





Kilews Power Torque Series Application Videos

<http://www.loover.com.tw/en/?p=1496>



Kilews Industrial Cordless Battery Electric Screwdriver





The features

1. Brushless motor.
2. Industrial tool.
3. Japanese high performance Li-ion battery.
4. The high-carbon steel material of clutch.
5. The materials of housing are made by Nylon and Fiber.
6. Durable and suitable for using in the adverse environment.

The main series

1. **Automatic:** max. torque as 60N.m
2. **Semi-Automatic:** max. torque as 12N.m
3. **Impact:** max. torque as 250N.m and perform as 3800 B.P.M.



The main series

1. Automatic series

a. Internal type

SKC-PTA-220/150/120/80

b. External type

SKC-PTA-B120/B90/B50F/B60/B35/B35F

c. **Counter with Wifi transmission**

SKC-PTA-BE120/BE90/BE50F

d. Angle type

SKC-PTA-L300/L600



Counter with Wifi transmission VS. Industry 4.0

● Feature of SKC-PTA-BE120/BE90/BE50F

- A. Built-in error proof function
- B. Display screw tightening status by LED and LCD
- C. I/O signals to PLC by KL-WSCBSN
- D. Input signal to control driver by PLC



● Feature of KL-WSCBSN

- A. Wifi transmission
- B. Error proof
- C. Prevent missing screw
- D. Distance control
- E. Tightening data storage
- F. Multi driver control
- G. Bar code reader



Integrate Production Schematic

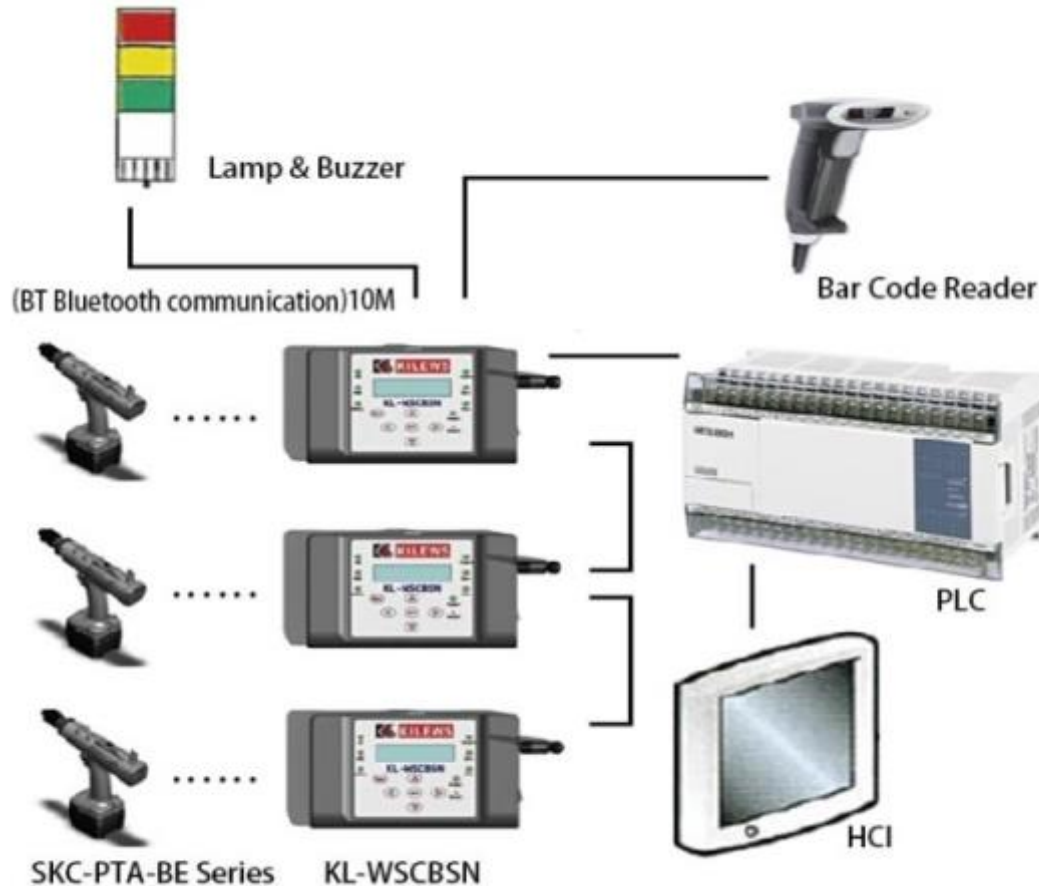

The main series

2. Semi-Automatic series

- SKC-PTS-120/80/50
- 23+MAX steps of torque adjustments
- 3 types of fasten speeds: Hi 100%, Mid 75%, Low 50%



The main series

3. Impact series

- SKC-PTI-250/160/100
- Use impact power to fix the screw, similar to semi-automatic series
- Use impact timing to control the torque:
 - Hi – impact for 5sec. (max. torque)
 - Mid – impact for 3sec. (medium torque)
 - Low – impact for 1sec. (min. torque)



Accessories

Charge Station

- Built-in LCD display shows recharging status
- Identify whether battery is supplied by Kilews
- Detect recharging time and battery capacity automatically

Rechargeable Batteries

- Japanese high performance Li-ion battery
- Built-in protection device to prevent battery overcharge and overdischarge
- Battery ID identification design



Application videos

Refrigerator assembly

https://youtu.be/Cr7mw_grMJE



Contact Info:



Kilews Industrial Co., Ltd.

No. 30, Lane 83, Huacheng Rd., Xinzhuang Dist., New Taipei City 242, Taiwan

Tel: +886-2-2997-1912 Fax: +886-2-2996-9023

E-mail: kilews@ms6.hinet.net

Website: <http://www.kilews.com/>



LOOVER INDUSTRIAL CO., LTD

Loover Industrial Co., Ltd. (Exporting Office)

1F, No. 13, Lane 219, Sec. 1, Fusing S. Rd., Taipei City 106, Taiwan

Tel: +886-2-2773-2311 Fax: +886-2-2741-5821

E-mail: loover@ms15.hinet.net

Website: <http://www.loover.com.tw/>



Thank You