



奇力速無碳刷電動起子(電批), (螺絲刀)

保用證客戶聯

保用範圍及條例

- 免費更換零件並不包括以下項目： ※ 請參考零件爆炸圖 (以手按式起子為圖例)
A：批咀 (起子頭) B：彈簧吊鉤 C：外殼 D：電源線 E：引導棒 F：陶瓷棒
G：消耗品等
- 無碳刷電動起子若非其他人為因素，每天正常使用 8 小時，馬達電機部分保用期為 3 年；若電動起子工作不限時數，馬達電機部分保用期則為 2 年；而整機部分不分工作時數，保用期為 1 年。
- 在下列情況下，保用將會自動失效：
 - 曾因錯誤，不正常操作，疏忽使用，意外事件或天災人禍而引致損壞。
 - 規格變動，我公司出廠時之起子規格為主，在保用範圍 (一年) 內，自行變更該起子之規格零件。
 - 機身號碼，保用證曾被轉換，塗改或除去，以致機身編號無法與保用證核對者。
 - 已轉換用戶或用戶遷址而未及時通知本公司者。
 - 自行更換非原廠提供之零件。
- 本公司將不負責任何由於保用產品損壞所招致直接或間接之損失。
- 本公司只在本公司辦公時間內提供保用服務，用戶如需其他時間提供者，在情況許可下，可作特別安排，但需按次加服務費。
- 除徵得本公司同意外，使用權利不得轉讓他人。
- 需妥善保用證及正式收據，並於維修服務時出示。

台灣維修部：新北市新莊區化成路 83 巷 30 號
電話：+886-2-2997-1912 傳真：+886-2-2996-9023
電子信箱：service@kilews.com.tw
網站：<http://www.kilews.com.tw>

其餘維修據點請參考以下網址
http://www.kilews.com.tw/tw_service.php



KILEWS BRUSHLESS ELECTRIC SCREWDRIVER WARRANTY CARD

TERMS & CONDITIONS

- The "Company" refers to Kilews free replacement of spare parts under normal usage except :
A).bit B).spring C).housing D).cord E).pilot rod F).ceramics rod G).consumables
※ Please refer to the part assembly drawing. (The example is push start type.)
- The warranty period of the motor is for 3 years based on 8 normal working hours per day. The warranty period of the motor is for 2 years based on un-limit working hours per day. The warranty of the whole screwdriver is for 1 year based on un-limit working hours per day.
- The warranty will be void and null if :
 - The product has been damaged due to misuse, abnormal operation, negligence, accident or a nature and man-made disaster.
 - It has been modified altered and or repaired by unauthorized person.
 - The serial number or the warranty card has been modified, effaced and or removed.
 - The Company was not promptly informed of any change of address or the ownership of the product(s).
 - Failing to use genuine parts that sold or recommended by the Company.
- The Company will be no liable for any direct or indirect loss arising from breakdown of the product(s).
- Under this warranty, the Company only provided for service at any time during normal business hours. Unavoidable emergency service may be requested outside normal business hours, such service if available will be provided and charged per call.
- The Warranty does not be allowed to transfer without the consent of the Company.
- Please keep and present the Official Receipt and Warranty Card to our technician for inspection during each service.

KILEWS MAINTENANCE CENTERS :

TAIWAN : NO.30, Lane 83, Hwa-Cheng Road, Hsin Chuang district, New Taipei City, Taiwan, R.O.C.
TEL : +886-2-2997-1912
FAX : +886-2-2996-9023
Email : service@kilews.com.tw
Web : <http://www.kilews.com.tw>

Other maintenance centers can be referred to the following homepage.
http://www.kilews.com.tw/en_service.php

MODEL NO 型 號 : _____
SERIAL NO 機身編號 : _____
Customer's Name 客戶名稱 : _____
Tel 電 話 : _____
Address 地 址 : _____
Date of Purchase 購買日期 : _____
Dealer's Ship 經銷商蓋章 : _____

※ 無碳刷電動起子零件爆炸圖

Brushless Electric Screwdriver Part Assembly Drawing

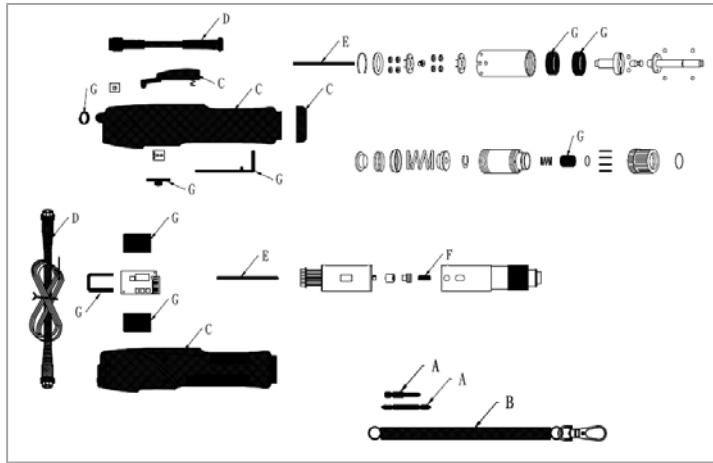

※ TB TBN 系列無碳刷電動起子零件爆炸圖

TB TBN Series Brushless Electric Screwdriver Part Assembly Drawing

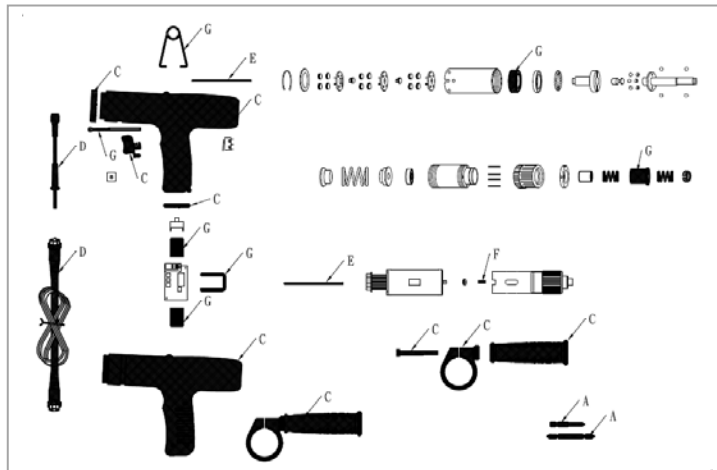

國際保用條款

1. 客戶購買奇力速電動起子無碳刷系列新產品如由於運送出口過程中，由本公司直接委託經銷商負責，則保證送到客戶指定地方簽收完成為止。客戶自己運輸過程中包括陸路、航空或海運，若有任何碰撞、損毀，本公司和國外分公司及代理商，無須負擔任何保證責任。如有上述任何運輸方式過程中損壞，使用者必須自付零件、維修費用等。
2. 使用者在台灣購買在台灣本地保證使用期間內正常損壞一切由奇力速負責，但使用者如自行攜帶到海外工廠使用，保證期間內零件費用免收費，但當地代理商或分公司需要酌收基本維修費用。
3. 海外維修保證期間內酌收基本維修費，應由使用者出示本公司保證卡與當地維修服務點商議，一切以客戶服務為主（但視修理數量、起子使用狀況、平均使用時間、工作量而來衡量）酌量收取費用。
4. 使用者在保證期間內如有問題要維修時，須提示保證卡。如無法明確出示完整保證卡，則視同保證期間過期無法保證，當地代理商在維修要按照本公司規定來收取零件及各項維修費用。
5. 超過保證卡上所載明的保證時間、日期，以後使用者不管在任何地方維修均要按照實際維修狀況來收取零件和維修費，最重要是本公司台灣經銷商、海外代理商、海外分公司，只要是奇力速公司出廠的電動起子（電批），也包括其它 OEM 廠牌公司所銷售的，本公司一定負責維修服務，且督促上述公司一定要秉著誠信服務的精神，確實的態度，來完成售後服務。如有服務不周的地方，歡迎不吝來電指教，本公司一定以顧客至上為宗旨，完善服務為目的，提供使用者一個完整的服務。感謝您支持本公司產品，本公司不勝感激。

INTERNATIONAL WARRANTY CONDITIONS

1. Purchases of Kilews Brushless Electric Screwdrivers for overseas destination shall be covered by the service warranty till the products are delivered to client-designated destinations, when and if dealers are directly entrusted by the Company to shoulder the responsibility. Any damage on the products arising from shipping of products handled by the buyers themselves shall not be included in the warranty, either by Company, its overseas branches or its dealers. Any such damage incurred during self-handled shipping shall be repaired with the buyer shouldering all parts and repair costs.
2. Malfunction of products bought in Taiwan, and used under normal conditions, shall be repaired fully at the Company's expense during the service warranty period. However, if the said products are abroad by buyers themselves for use in overseas factories, the Company's local branches or dealers shall charge basic repair fees. Within the warranty period, however, no cost for parts replacements shall be charged.
3. During the service warranty period, products sent overseas shall, in principle, be charged basic repair expenses. The buyer shall present the warranty card issued by our company and negotiate with the repair and maintenance shop. In principle, customer service shall be given due emphasis. Reasonable fees shall be charged to the buyer after consideration of such factors as the number of pieces to be repaired, delivery distance, actual state of the screwdrivers, approximate duration of usage and work load.
4. During the service warranty period, users shall present warranty cards for requesting repair of malfunctioning products. Failure to present a complete warranty cards shall be considered as expiration of the card and non-entitlement to free warranty service. Repair and maintenance in such a case would allow dealers to charge the user costs of replaced parts and all repair expenses based on conditions set by the Company.
5. Beyond the dates and time specified in the warranty card, all repairs of products conducted anywhere in the world shall be charged all actual material and repair costs. More importantly, the Company's Taiwan dealers, overseas distributors overseas branches shall handle repair and maintenance work of all Kilews Electric Screwdriver products, including those sold by OEM-brand companies. The Company, Shall in principle, uphold the spirit of honest client service and practical attitude to provide after-sales service to its clients.

We welcome buyers opinions on service quality. We shall give due importance to buyers in providing a sound and complete after-sales service. Thank you for using our product.