

suction nozzle DIM					
PART NO	d1	d2	D	H	Bit Dim (mm) T x D x L
P11032	2.2	3	4	1.3	00 x 1.5 x 60
P11032-1	2.7	4	5	1.5	0 x 2.0 x 60
P11032-2	3.2	4.5	5.5	2	1 x 2.5 x 60

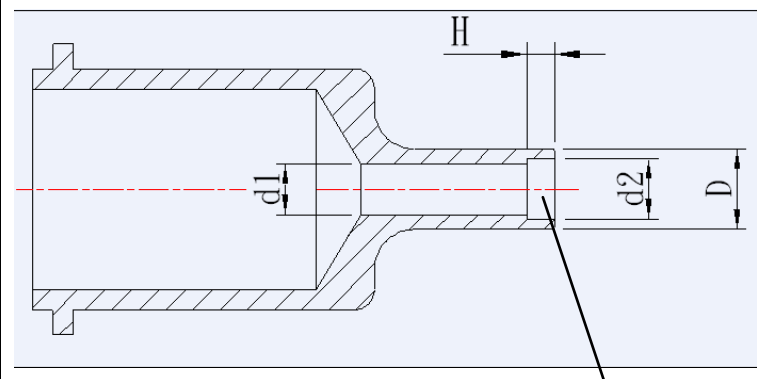

Maximum size for screw head

螺絲頭卡在吸嘴頭時,卡槽深度

“H” where screws would be stuck in

吸嘴孔道的大小,氣會通過的地方,
螺絲不會進到此處 D1,blow nozzle, air could
go through. Screws are not supposed to get in.

起子頭縮小的圓徑,會與 d1 保持空間,讓
氣通過 Bit dimension